



# **RADIATOR GUARD**

## **Installation Instructions**

**YAMAHA MT 07**

**MODEL YEAR 2018+**

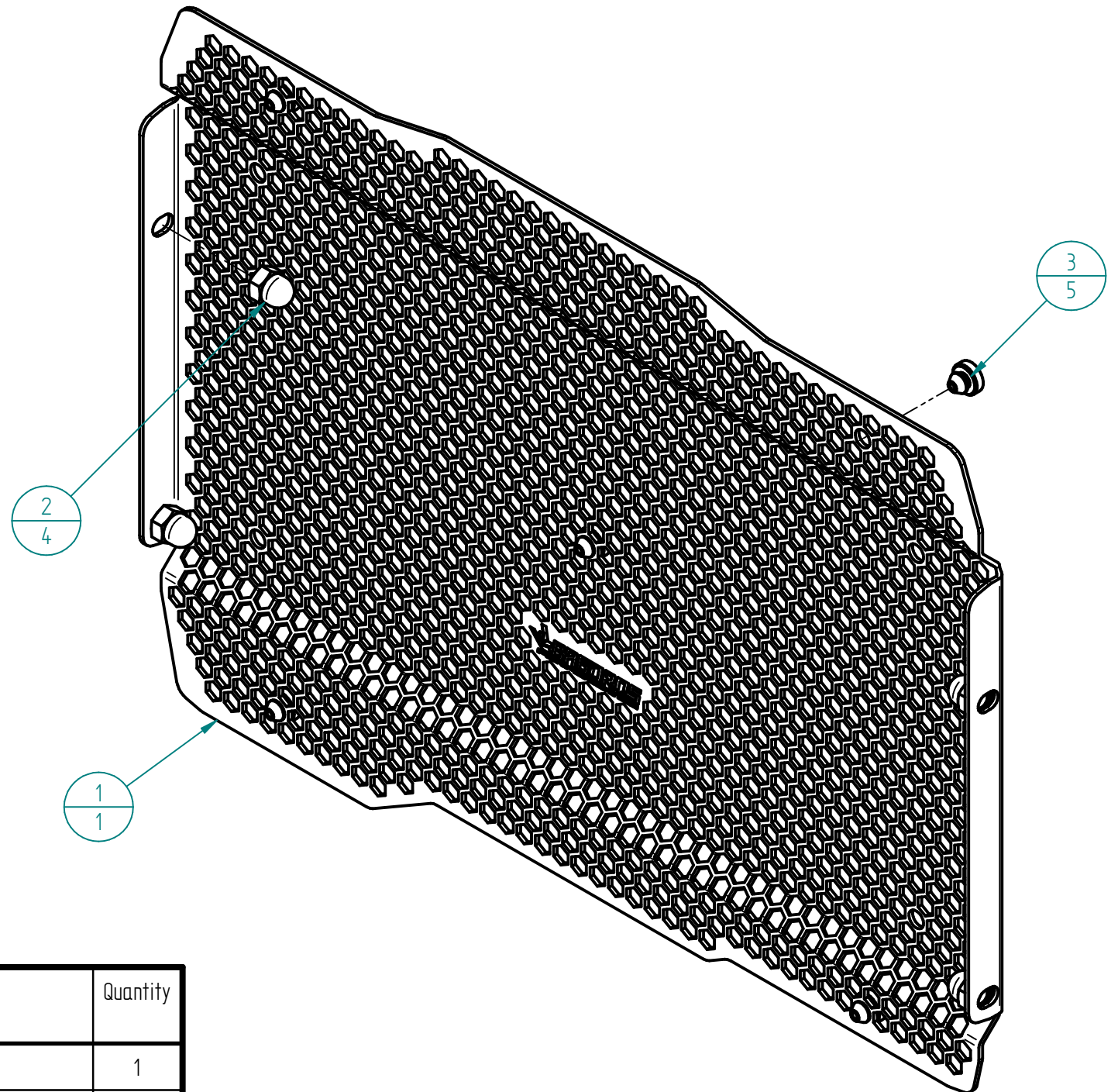

Item Number	Title	Quantity
1	Mesh	1
2	Domed Cap Nut   M6   DIN1587   ISO/	4
3	Flexible bumper	9

# STEP 1

Remove the OEM bolts using a allen key. Repeat for other side.



# STEP 2

Remove the 2 clip nuts on each side and put them to the side, because they will not fit the new BP Radiator Guard.

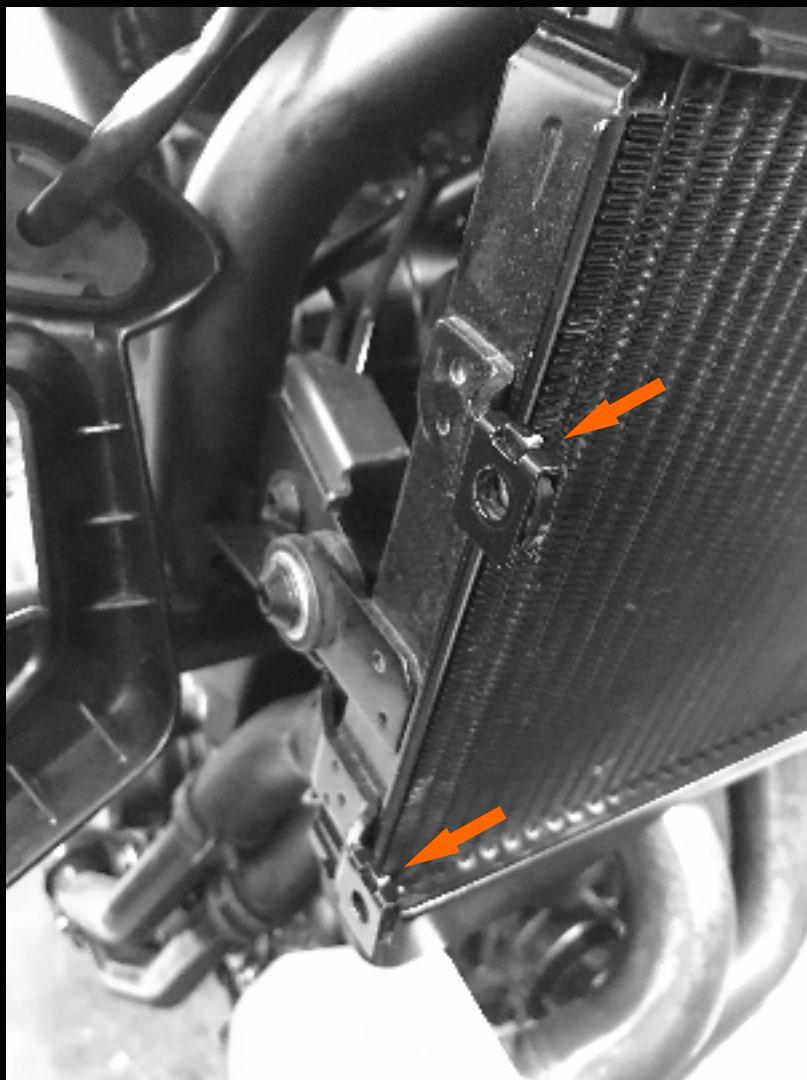

# STEP 3

Take the 3D printed bumpers and place them inside the radiator guard as shown in the photo.

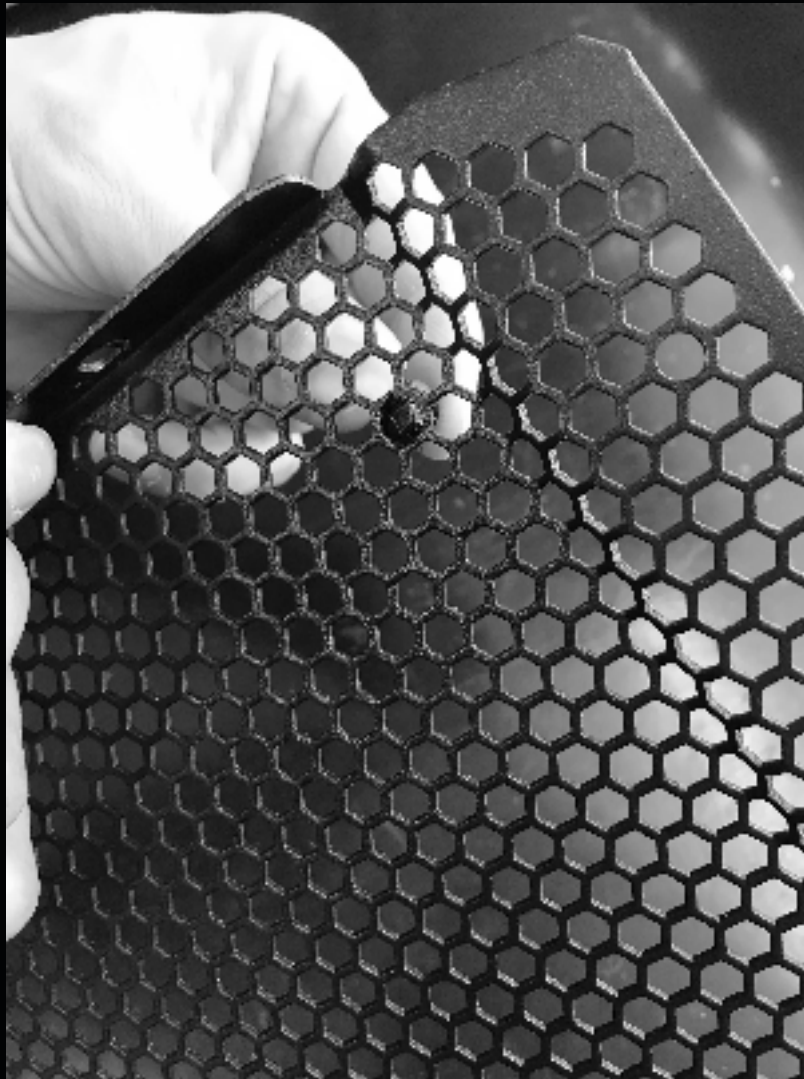

# STEP 3

Align the radiator guard with the existing holes. Put back the decorative plastic and push the screws through and add the cap nuts provided in the kit. Repeat for other side.



# **STEP**4

**Congratulations you've pass the finish line. Now your Radiator is protected and it's all thanks to you!**

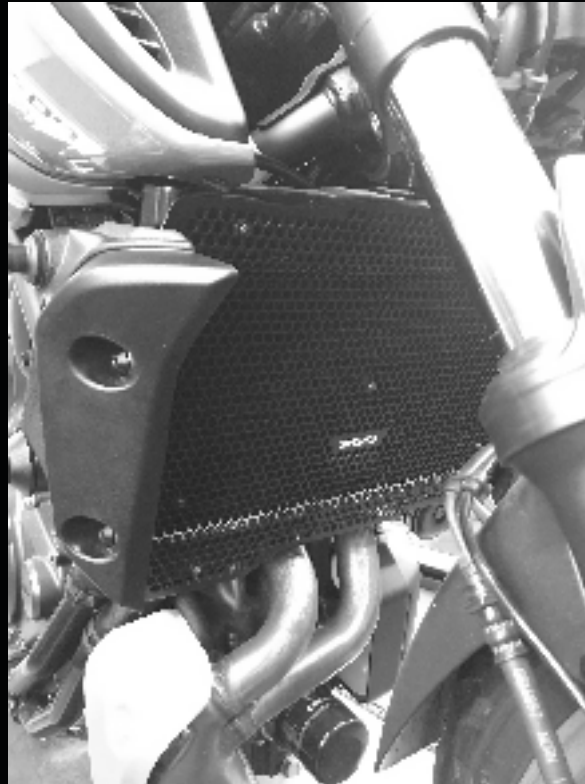

## **IMPORTANT**

**It is recommended that periodic inspections are made to ensure that all bolts are tightened to the specified torque settings. Should the bike be involved in an accident a thorough inspection should be made and any components that have taken an impact, no matter how small, be replaced.**

**The manufacturer or supplier cannot be held responsible for products that are incorrectly mounted or inappropriately used.**

**It is recommended to check all connections regularly for tightness of fit.**



**<https://bagorosperformance.com/product/radiator-guard-for-yamaha/>**

A decorative graphic consisting of several parallel, slanted grey bars of varying lengths, positioned in the bottom right corner of the page.